

Features

- ★ Small Footprint
- ★ In-Out Isolation Voltage 4500 VDC
- ★ (7 PIN) SIP Package
- ★ Temperature Range:-40°C to +85°C
- ★ UL94V-0 Inflamming retarding package
- ★ MTBF>1million hours(25°C)



Applications

The H_S-2W Series are designed for application where isolated output is required from a distributed power system.

These products apply to where:

- 1) 4500 VDC input and output isolation;
- 2) Input voltage variation $\leq \pm 10\%$;
- 3) Regulated and low ripple noise is not required.

Such as: digital circuits, and IGBT power device driving circuits.

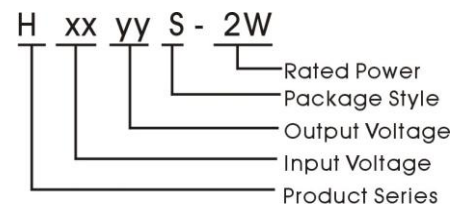

Model Detail List Specification

Model Number	Input Voltage range (nominal voltage)	Output Voltage	Output Current (mA)		Input Current full load. (mA)		Efficiency	Max. Capacitive Load(μ F)
			Min.	Max.	Max.	Min.		
H0505S-2W	4.5~5.5VDC (5 VDC)	5.0V	40	400	493	40	81%	400
H0509S-2W		9.0V	22	222	481		83%	
H0512S-2W		12.0V	16	167	477		84%	
H0515S-2W		15.0V	13	133	469		85%	
H1205S-2W	10.8~13.2VDC (12 VDC)	5.0V	40	400	203	38	82%	
H1209S-2W		9.0V	22	222	200		83%	
H1212S-2W		12.0V	16	167	198		84%	
H1215S-2W		15.0V	13	133	195		85%	
H2405S-2W	21.6~26.4VDC (24 VDC)	5.0V	40	400	101	30	82%	
H2409S-2W		9.0V	22	222	99		84%	
H2412S-2W		12.0V	16	167	98		85%	
H2415S-2W		15.0V	13	133	96		86%	

Common Specifications

Item	Test Conditions	Min.	Typ.	Max.	Unit
Isolation Voltage	Tested for 1 minute and leakage current less than 1 mA	4500			VDC
Switching Frequency	Full load, nominal input		100		KHz
MTBF	MIL-HDBK-217F@25°C	1000			K hours
Isolation Resistance	Test at 500VDC	1000			M Ω
Isolation Capacitance			300		pF
Weight			2.5		g

Output Specifications

Item	Test Conditions	Min.	Typ.	Max.	Unit
Output Power		0.2		2	W
Line Voltage Regulation	For Vin change of $\pm 1\%$			± 1.5	%
Load regulation	10% to 100% load	5V output	10	15	
		12V output	8	15	
		15V output	6	15	
		24V output	6	15	
Ripple	20MHz Bandwidth		50		mVp-p
Noise			75		
Temperature Drift	100% full load			± 0.03	%/°C
Input Filter		C Filter			

Input Specifications

Item	Test Conditions	Min.	Typ.	Max.	Unit
Input Max. voltage	5 VDC Input (4.5~5.5V)			6	VDC
	12 VDC Input (10.8~13.2V)			14.4	
	24 VDC Input (21.6~26.4V)			28.8	
Input surge voltage (1 sec. Max.)	5 VDC Input (4.5~5.5V)	-0.8		10	VDC
	12 VDC Input (10.8~13.2V)	-0.8		20	
	24 VDC Input (21.6~26.4V)	-0.8		32	

Product typical Curve

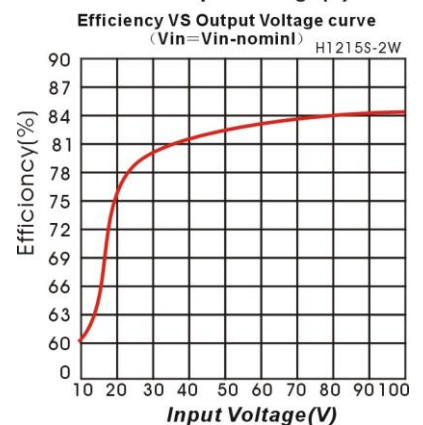
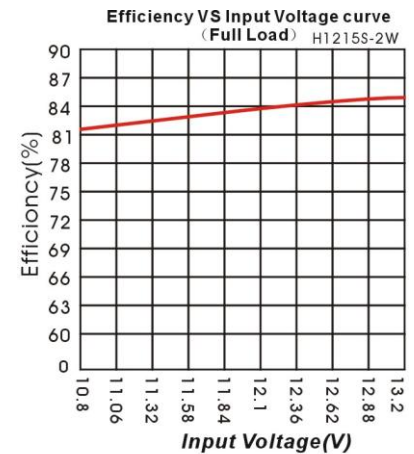

Environmental Specifications

Item	Test Conditions	Min.	Typ.	Max.	Unit
Storage Humidity	Non condensing			95	%
Temp. rise at full load			25	45	°C
Operating Temperature		-40		+85	
Storage Temperature	Power derating (above 85°C)	-55		+125	
Soldering Temperature	1.5mm from case for 10 seconds			300	
Cooling		Free air convection			

Mechanical Dimensions & Recommended Footprint

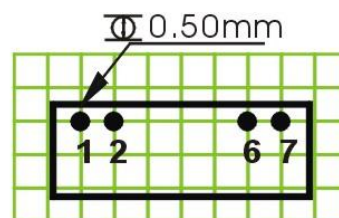
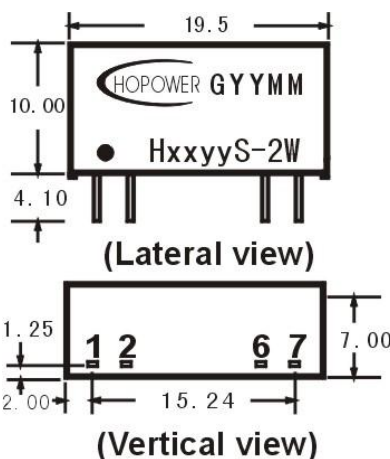

Note: Grid 2.54*2.54mm.
Unit: mm
General tolerances : 0.20mm

Package	Vin	GND	OV	+Vo
HS	1	2	6	7

Tolerance Envelope Curve & Temperature Derating Graph

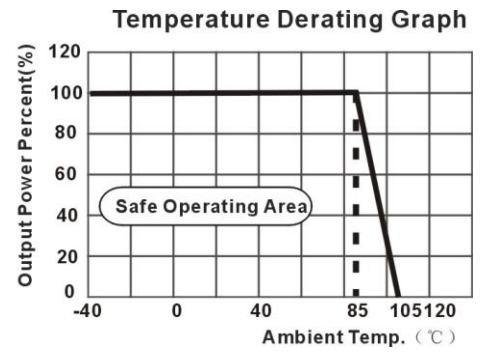
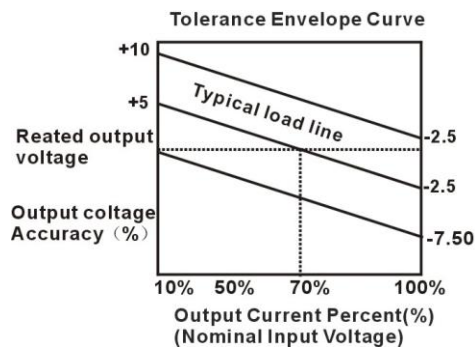

EMC Recommended Circuit

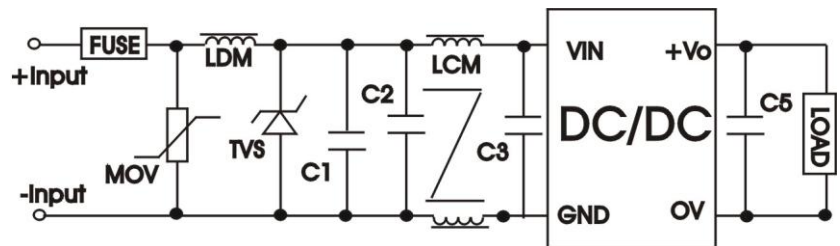

EMC Module Application Circuit

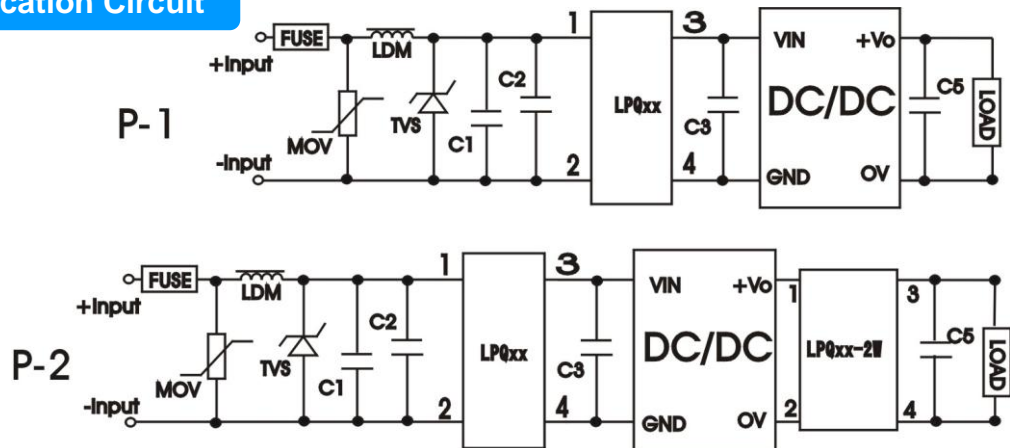

Model test Circuit

